

ELECTRICAL SCHEMATIC - FORD 1.3L GASOLINE

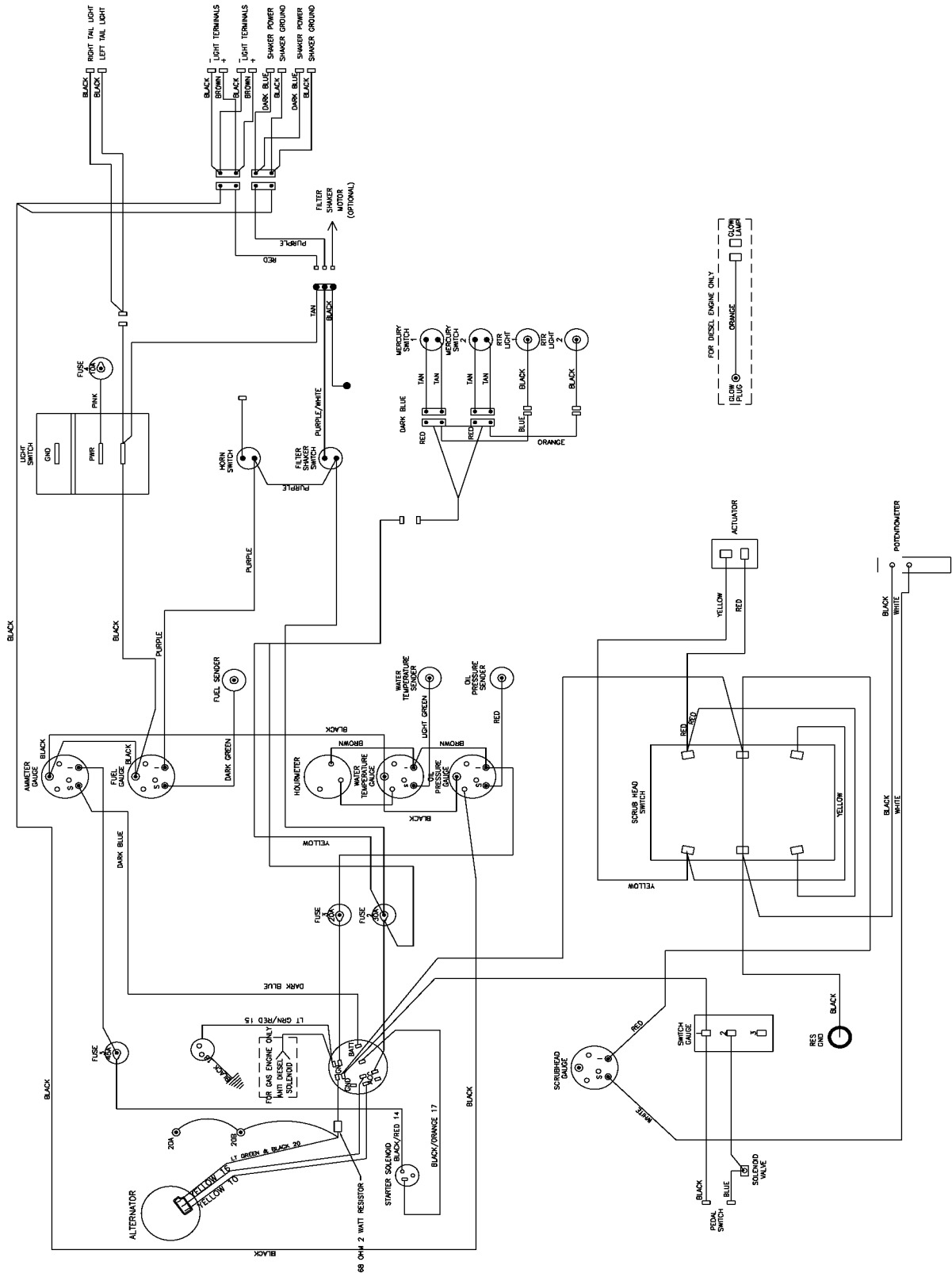

ELECTRICAL SCHEMATIC - PERKINS 104-19 DIESEL

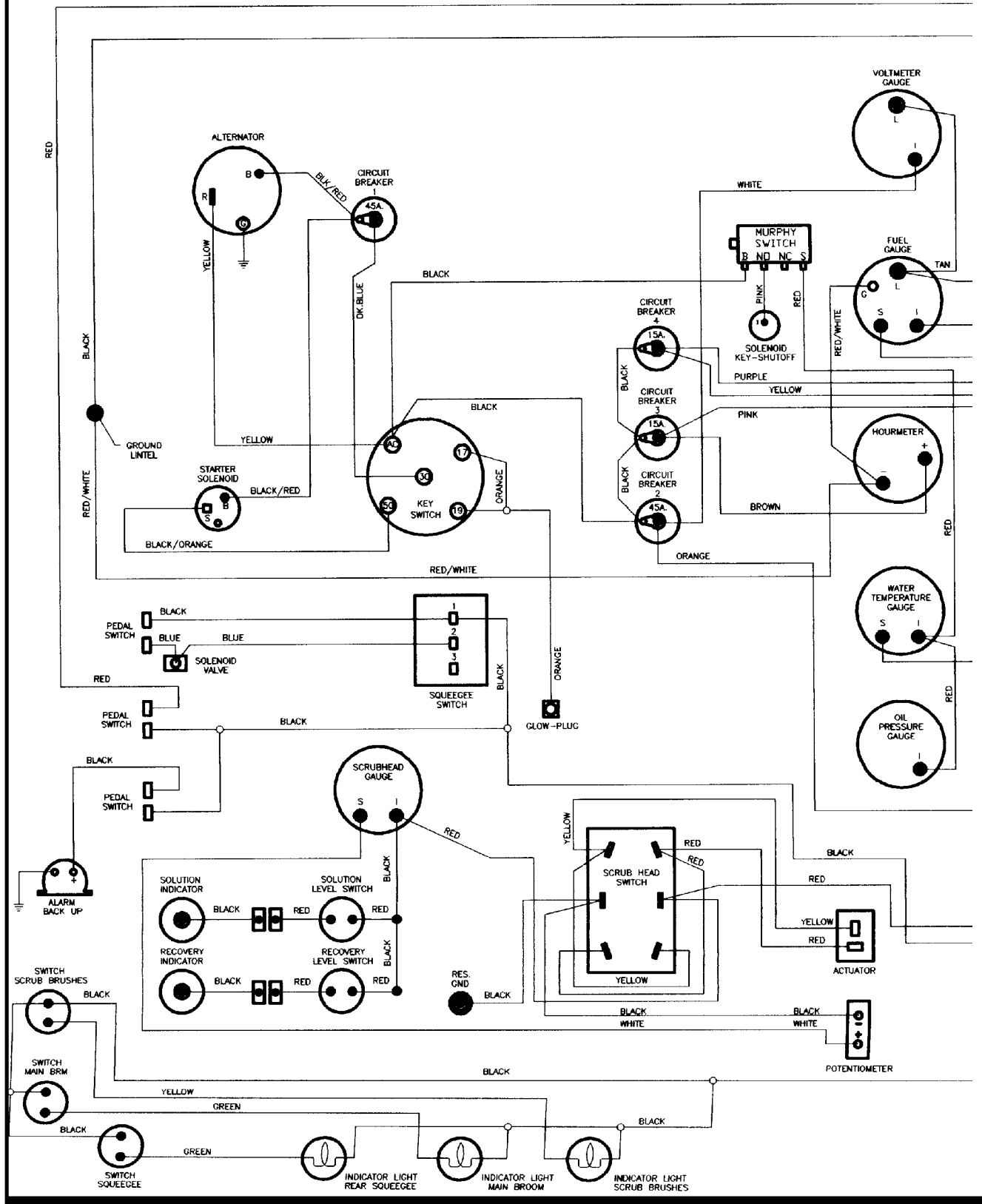

ELECTRICAL SCHEMATIC - PERKINS 104-19 DIESEL

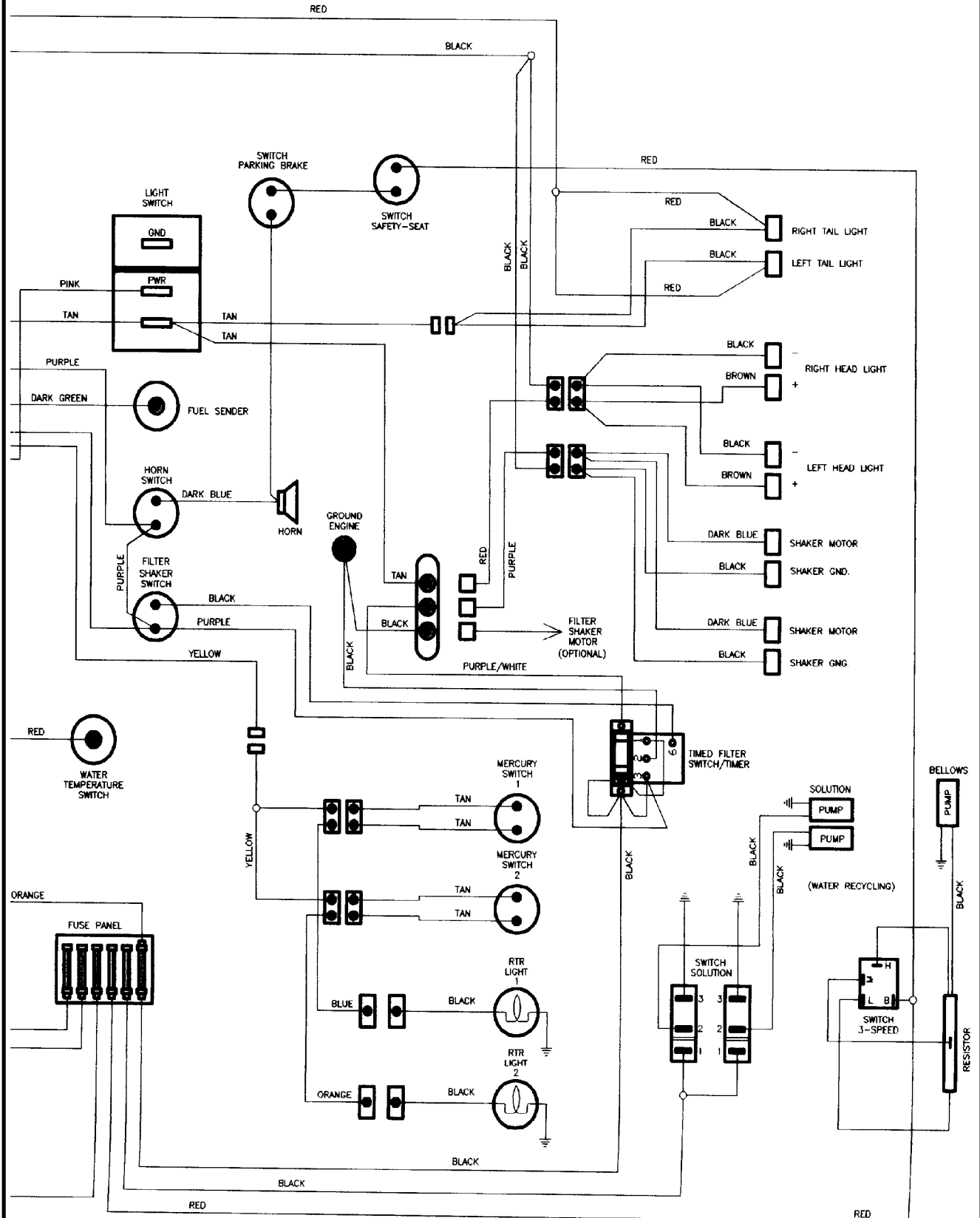

ELECTRICAL SCHEMATIC - KUBOTA DIESEL

